

# Super Brightness Red LED Lamp

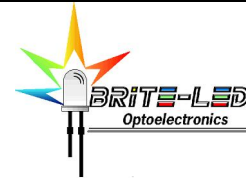

5mm Round Through-Hole Package

## PL-LSRE5B18C series

FEATURES	APPLICATIONS
<ul style="list-style-type: none"> <li>• Super luminosity Red 626nm LED</li> <li>• Latest AlInGaP II die (TS).</li> <li>• 5mm round resin mold.</li> <li>• Water Clear Lens.</li> <li>• UV Resistant Epoxy for outdoor use.</li> </ul>	<ul style="list-style-type: none"> <li>• Traffic and Railroad signals.</li> <li>• Outdoor Score/Clock Boards</li> <li>• Full Color RGB Video Displays</li> <li>• Back or Side lighting.</li> <li>• Automotive.</li> </ul>

### PACKAGE OUTLINE DIMENSIONS:

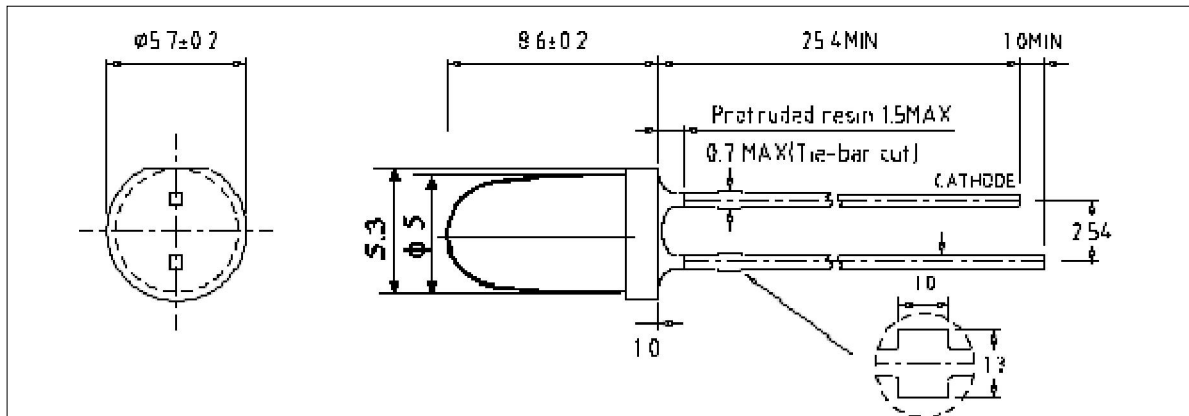

Lead Stoppers Optional

#### NOTES:

1. All dimensions are in millimeters.
2. Tolerance is  $\pm 0.25$  mm unless otherwise noted.
3. Lead spacing is measured where the leads emerge from the package.
4. Specifications are subject to change without notice.

### BEAM RADIATION PATTERN

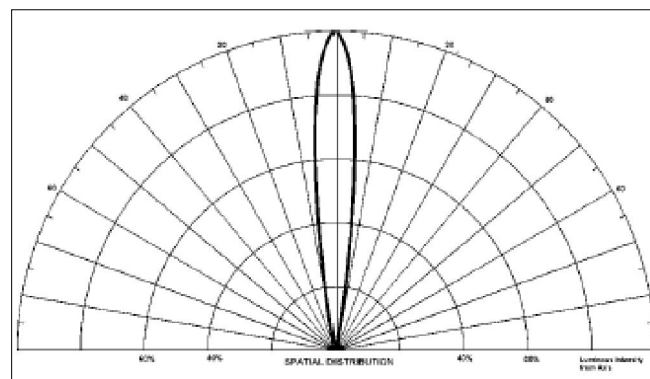

# Super Brightness Red LED Lamp

5mm Round Through-Hole Package

## PL-LSRE5B18C series

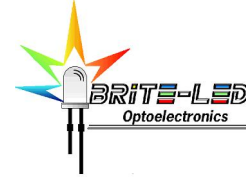

### ABSOLUTE MAXIMUM RATING (at $T_A = 25^\circ\text{C}$ )

Parameter	Symbol	Value	Unit
Continuous Forward Current	$I_F$	50	mA
Peak Forward Current (1/16 Duty Cycle, 0.1 msec Pulse width)	$I_{Fp}$	150	mA
Power Dissipation	$P_d$	130	mW
Forward Voltage	$V_f$	2.6	V
Derating Factor	$D_F$	0.4	mA / $^\circ\text{C}$
Reverse Voltage	$V_R$	5.0	V
Operating Temperature	$T_{opr}$	-25 to +85	$^\circ\text{C}$
Storage Temperature	$T_{stg}$	-35 to +100	$^\circ\text{C}$
Lead Soldering Temperature (1.6mm (0.063") from body)	260 $^\circ\text{C}$ for 5 seconds		

### ELECTRICAL / OPTICAL CHARACTERISTICS (at $T_A = 25^\circ\text{C}$ )

Parameter	Symbol	Min	Typ	Max	Unit
Forward Voltage	$I_F = 20\text{ mA}$ $V_F$	1.9	2.2	2.4	V
Dominant Wavelength	$I_F = 20\text{ mA}$ $\lambda_d$		626		nm
Peak Wavelength	$I_F = 20\text{ mA}$ $\lambda_p$		634		nm
Spectrum Radiation Bandwidth	$I_F = 20\text{ mA}$ $\Delta\lambda$		17		nm
Reverse Current	$V_R = 5\text{ V}$ $I_R$			100	$\mu\text{A}$
Viewing Angle	$2\theta_{1/2}$	15	18	21	deg
Luminous Intensity	$I_F = 20\text{ mA}$ $I_v$	5500	7500	12000	mcd

# Super Brightness Red LED Lamp

5mm Round Through-Hole Package

**PL-LSRE5B18C series**

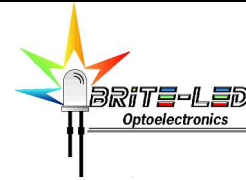

## TYPICAL ELECTRICAL CHARACTERISTICS CURVES (at 20 mA DC / $T_A = 25^\circ\text{C}$ )

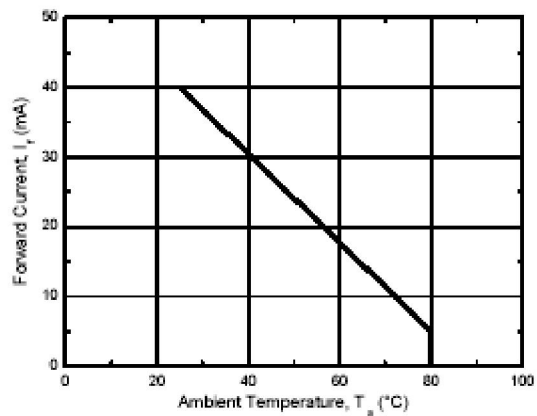
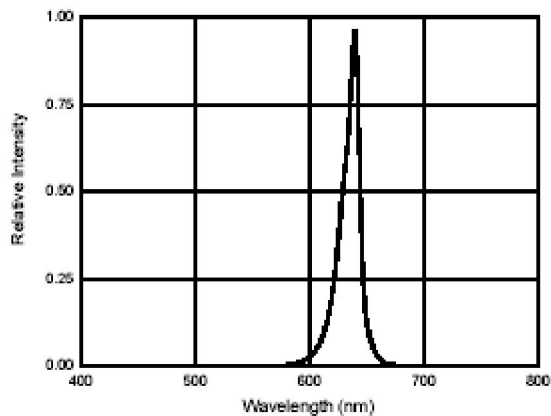
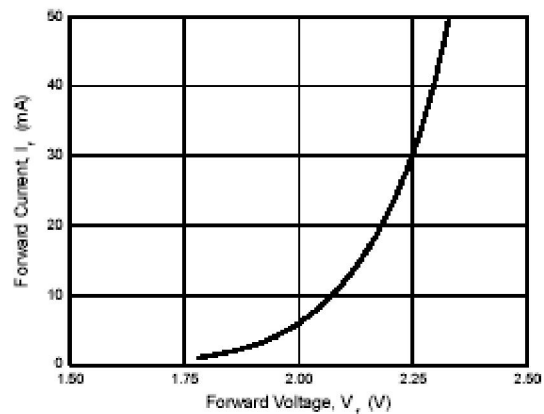
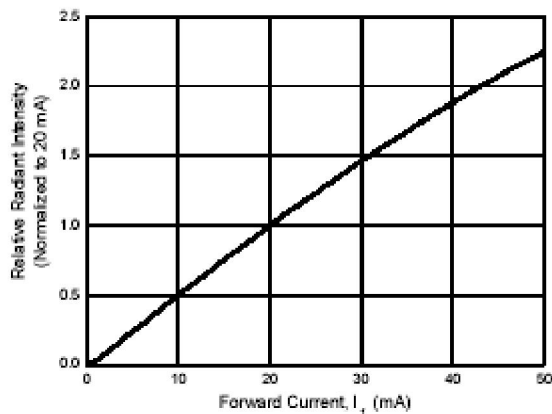

### GENERAL NOTES:

1. Luminous Intensity ( $I_v$ ) is measured with a light sensor and filter combination (goniospectroradiometer) and is the Luminous Flux per unit solid angle (steradian) emitted by the LED lamp in the direction of the mechanical axis of the lamp and then weighed by the eye response curve (1931 CIE 2° Observer Chromaticity Diagram).
2. Luminous Intensity measurement uncertainty is  $\pm 15\%$  due to test procedures and equipment variations.
3.  $\theta_{1/2}$  is the off-axis angle at which the luminous intensity is half the axial luminous intensity. Tolerance  $\pm 3^\circ$ .
4. Dominant wavelength is derived from the 1931 CIE 2° Observer Chromaticity Diagram.
5. Peak and Dominant wavelength measurement uncertainty is  $\pm 0.05$  due to variations.
6. Caution for ESD: Static Electricity and surges can damage the LED. It is recommended using a wristband or anti-electrostatic glove when handling the LED. All devices, equipment and machinery must be properly grounded.
7. Do not apply excess mechanical stress to the leads, especially when heated or while soldering.

# Super Brightness Red LED Lamp

5mm Round Through-Hole Package

## PL-LSRE5B18C series

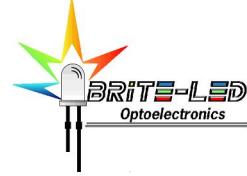

### PRODUCT CODE BREAKDOWN

